



OWNER'S MANUAL

Secondary Brake Device Mounting & Operating Instructions



Table of Contents

1.1 Technical Parameters of Starke Secondary Brake Device	3
1.2 Operating Principle and Structural Features	3
1.2.1 External View of Secondary Brake Device	4
1.2.2 Internal View of Secondary Brake Device	5
2.0 Mounting and Delivery	6
2.1 Items to Check Before Mounting	6
2.2 Mounting and Requirements	7
3.0 Secondary Brake Device Dimensions	7
4.0 Operation Warnings	8
4.1 Items to Check Before Use	8
5.0 Functional Description	8
6.0 Operating Instructions	9
7.0 Dismantling	9
8.0 Care and Maintenance	10
8.1 Check Before Each Use	10
8.2 Daily Maintenance	10
8.3 Annual Inspection	10
8.4 Bi-Annual Recertification	10
8.5 Maintenance	11
9.0 Wearing Parts	12
10.0 Handling and Storage	12
10.1 Transportation	12
10.2 Storage	12
11.0 Electrical Wiring Diagram (Optional Attachment)	13
Starke Products Warranty	14

1.1 Technical Parameters of Starke Secondary Brake Device

Model	Wire Rope Diameter (mm)	Rated Load Capacity	Lock Speed
S2KLAS	10.2	2,204 lb	80 FPM
S3KLAS	11.5	3,527 lb	80 FPM
Normal Operating Conditions	Ambient temperature: 14° Fahrenheit to 131° Fahrenheit		
	Ambient relative humidity: ≤90% (at 77° Fahrenheit)		

1.2 Operating Principle and Structural Features

The centrifugally triggered secondary brake device consists of the lock rope mechanism, unlocking assembly, locking assembly, wire rope press assembly, centrifugal overspeed mechanism, and other components. The operation of the brake device is based upon the principle of centrifugal speed limit. The wire rope runs through the pulley that is connected to the centrifugal overspeed mechanism. When the falling speed exceeds the limit, the pulley turns quickly to enable the swing block of the centrifugal overspeed mechanism to trigger the rope locking mechanism. Then the rope clip locks the safety wire rope swiftly.

Optional accessory: Lock wire rope power-off protection device that is to install a micro switch in the safety lock. When the safety lock locks the rope, the micro switch will be triggered, and sends a signal to the electrical control system to cut off the power.

1.2.1 External View of Secondary Brake Device

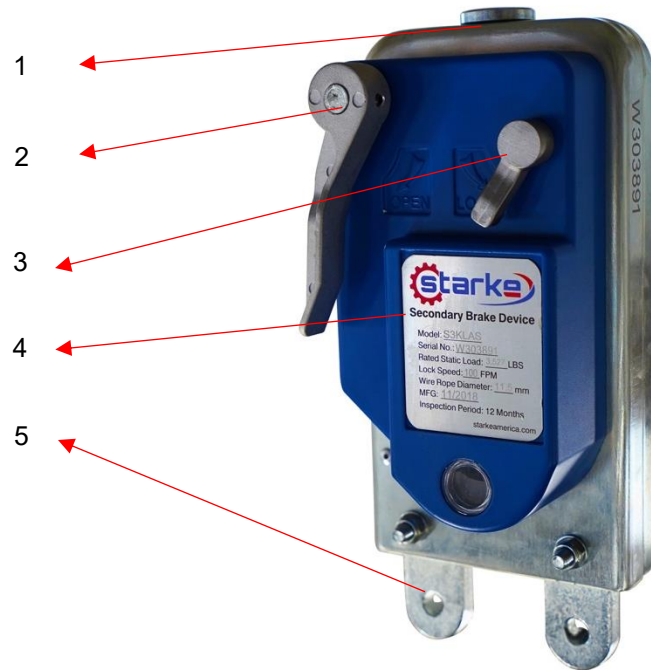

Drawing No.	Part Description
1	Wire Rope Inlet
2	Unlocking Lever
3	Locking Lever
4	Cover
5	Bracket

1.2.2 Internal View of Secondary Brake Device

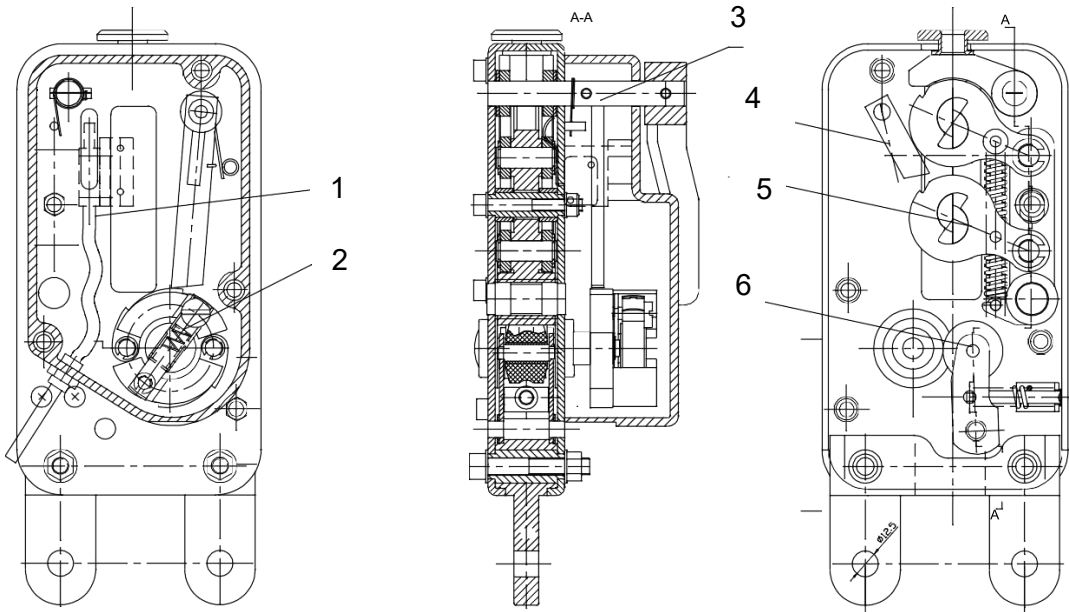

Drawing No.	Part Description
1	Rope Locked Switch
2	Centrifugal Overspeed Mechanism
3	Unlocking Assembly
4	Locking Assembly
5	Lock Wire Rope Mechanism
6	Wire Rope Press Assembly

2.0 Mounting and Delivery

- Danger of injuries due to falling objects, malfunction, or incorrect mounting.
- Danger of being pierced or cut.
- Please read the operating instructions carefully before mounting.
- Please wear safety gloves before any work on the wire rope.
- Do not touch the wire rope when the secondary brake device is activated.
- Do not touch the rope inlet of the secondary brake device.
- Keep a safe distance from the wire rope.
- Do not allow the wire rope to become tangled.
- Do not handle the running wire rope with your hands.

2.1 Items to Check Before Mounting

No.	Items	Results	Remark
1	Check if the brake device and fittings are complete.		
2	Check if the brake device is damaged.		
3	Check if the casing of the brake device is deformed.		
4	Check if the wire rope diameter and structure are compatible with the brake device.		
5	Check if the wire rope is damaged.		
6	Check if name plate is visible after mounting.		

2.2 Mounting and Requirements

- The mounting shall be conducted by personnel that have been properly trained.
- The maximum impact force shall be within the permissible range of the secondary brake device.
- The size of the mounting hole shall match the mounting dimensions of the secondary brake device.
- Fixation of secondary brake device
 - Use M12 bolts – 10.9 (Grade 8)
 - Use self-locking nuts to avoid missing and disengagement.
- The wire rope shall be inserted into the secondary brake device vertically.
- The actual working conditions shall meet the requirements for operating conditions of the secondary brake device.
- The wire rope must be taut with either a free hanging weight or tun buckle configuration.

3.0 Secondary Brake Device Dimensions

The following sketches illustrate the dimensions of the S2KLAS & S3KLAS:



4.0 Operation Warnings

- Risk of serious accident.
- Danger of being injured by falling objects.
- Do not permit the continuous use of the secondary brake device.
- Do not permit use in an explosive area.
- Please read the operating instructions carefully before operating.
- Do not lean on the secondary brake device during use.
- Do not touch the wire rope or the wire rope inlet while the secondary brake device is activated.

4.1 Items to Check Before Use

No.	Items	Results	Remark
1	Check if the wire rope is fully secured.		
2	Check if the wire rope is damaged.		
3	Check if the wire rope is contaminated. If contaminated, clean the wire rope.		
4	Check if all connecting bolts are fastened securely.		
5	Perform the wire rope locking test on the brake device.		

Locking test: Pull the wire rope quickly above the unlocked brake device. If the brake device is locked immediately, it indicates that the wire rope locking mechanism functions normally. From the sight window of the brake device, check that the centrifugal overspeed mechanism rotates at a constant rate when the platform is being lifted or lowered. If the centrifugal overspeed mechanism rotates unevenly or is seized, remove it for inspection and repair.

5.0 Functional Description

The centrifugal secondary brake device is an independent mechanical device triggered by speed. When the suspension rope of the lifting platform is broken or the lifting platform falls quickly, the secondary brake device will lock the wire rope and inhibit the lifting platform from falling.

6.0 Operating Instructions

Mount the secondary brake device at the desired position. Turn the “Unlocking Lever” clockwise to open the secondary brake device. Insert the wire rope from the “Rope Inlet” at the top of the brake device through the “Rope Outlet” at the bottom of the brake device. Tighten the rope and fix a heavy weight or tun buckle. Now the brake device can be put into use.

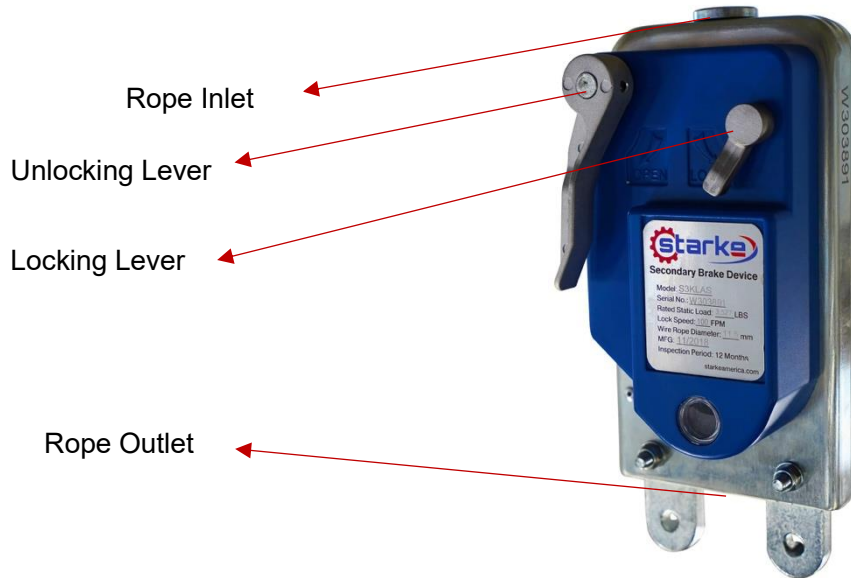

If it is necessary to lock the safety wire rope manually, turn the “Locking Lever” counterclockwise. A “click” indicates that the wire rope is locked by the wire rope locking mechanism.

▲IMPORTANT NOTE: Do not lock the safety wire rope when in use.

7.0 Dismantling

The dismantling shall be conducted by a person that has been properly trained. Safety gloves and required tools are necessary.

8.0 Care and Maintenance

- Do not lubricate the wire rope with disulphide containing lubricants.
- Please wear safety gloves before any work on a wire rope.
- Do not clean the wire rope or the secondary brake device with a high-pressure cleaner.

Maintenance activities include an inspection before each use, daily maintenance, annual inspection, bi-annual recertification, and others. Users are responsible for daily maintenance and inspection. Annual inspections must be done by qualified personnel. All maintenance activities must be recorded and signed.

8.1 Check Before Each Use

Please refer to 3.1 for the list of items to check before use.

8.2 Daily Maintenance

The daily maintenance does not cover the replacement of parts. Users shall clean and maintain the secondary brake device as scheduled. Remove any dirt on the wire rope and brake device as well as rust on the wire rope, if possible.

8.3 Annual Inspection

Annual Inspection Periods:

Under normal circumstances, a secondary brake device must be inspected once a year. The annual inspection of a secondary brake device must be completed by a qualified person approved by Starke, otherwise the liability will be placed upon the end user. The replacement parts must be OEM Starke components.

The contents of the annual inspection include:

- Clean the outside of the secondary brake device.
- Check and replacement of wearing parts such as pressure wheel and centrifugal trigger.
- Test and adjust wire rope locking speed.

8.4 Bi-Annual Recertification

- Must be conducted bi-annually or 500 hours of operation.
- Clean the inside of the secondary brake device.
- Perform calibration of secondary brake device.

8.5 Maintenance

Maintenance items are detailed in the following table:

Interval	Maintenance items	Responsible Person
Every Day (Daily Check)	<ol style="list-style-type: none">1. Check if the brake device is fastened.2. Check if the wire rope is contaminated.3. Check if all bolts are tightened.4. Check if the brake device generates any abnormal sound.	User
Every Week	<ol style="list-style-type: none">1. Check if the brake device is fastened.2. Check the wire rope.	Operator
Two Year	Bi-annual calibration of brake device	Authorized Personnel
When Needed	<ol style="list-style-type: none">1. Clean the wire rope2. Replace the wire rope	Authorized Personnel
When Needed	Adjust the wire rope locking speed	Authorized Personnel

Conduct an overall maintenance and inspection after each project use.

9.0 Wearing Parts

No.	Parts Name	Article Number in Drawing
1	Rope Pressing Wheel	39
2	Rope Pressing Rolling Wheel	12
3	Outside Wire Rope Clip	26
4	Inside Wire Rope Clip	25

10.0 Handling and Storage

10.1 Transportation

Protect the secondary brake device from damage during transportation. Pack the secondary brake device in the carton for vehicle transport.

10.2 Storage

The secondary brake device must be stored in a dry and dust-free place at a stable temperature.

11.0 Electrical Wiring Diagram (Optional Attachment)

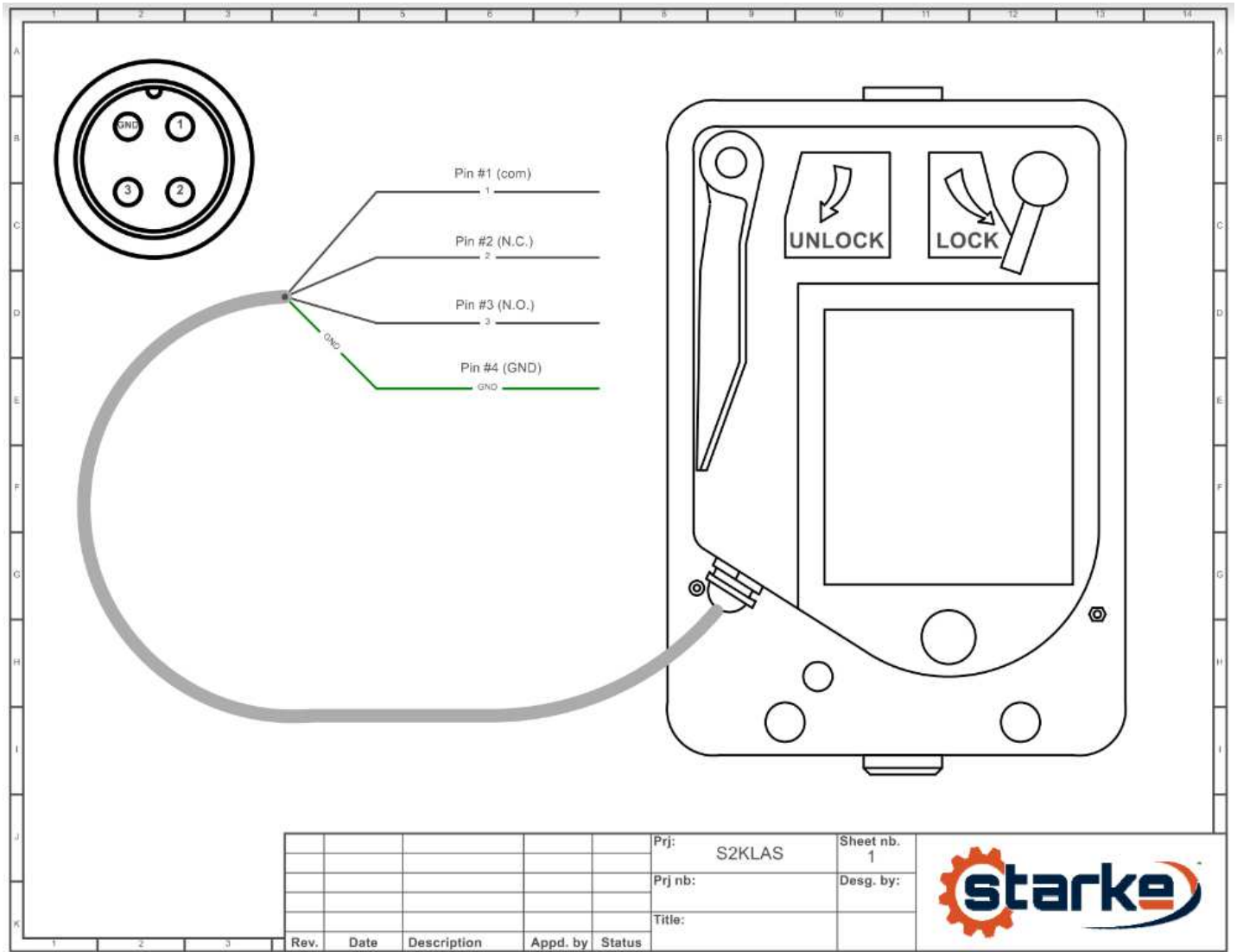



Starke Products Warranty

1 Year (12 Month) Parts & Labor Warranty

Unless otherwise specified, Starke guarantees that our products are free from material defects in design and workmanship under normal use, proper maintenance, and service.

This warranty is strictly limited to 12 months for single shift operation or 2,000 hours after installation, or 14 months after shipment, whichever is shorter. Within ten days after defect is found, warrantee must deliver a written notice to Starke providing defect information. All requested warranty information must be received promptly by Starke in no more than 5 business days.

Customer is responsible for all shipping charges on returned/warrantable items. Starke will cover the repair (parts and labor) at no charge or provide a replacement item at Starke's discretion.

This warranty does not cover defects or damage caused by acts of God, unusual wear and tear, improper use, or improper maintenance by the user. No responsibility for consequential damage is expressed or implied, and the responsibility under this warranty/guaranty is limited to the repair or replacement of the defective materials. Repair or replacement of the item is fully at the discretion of Starke.

ALL OTHER REPRESENTATIONS, EXPRESS OR IMPLIED, WARRANTY, OR LIABILITY RELATING TO THE CONDITION OR USE OF THE PRODUCT ARE SPECIFICALLY DISAVOWED, AND IN NO EVENT SHALL STARKE BE LIABLE TO BUYER, OR ANY THIRD PARTY, FOR ANY DIRECT OR INDIRECT CONSEQUENTIAL OR INCIDENTAL DAMAGES

STARKE

Starkeamerica.com/contact-us/



Contact Your Starke Representative for More Information on Products to Help Maximize Your Workplace Efficiency



Hoists & Trolleys



Crane Components



Electrification



Crane Kits



Slings



Safety

