

MOTORIZED TROLLEY

KEY COMPONENTS

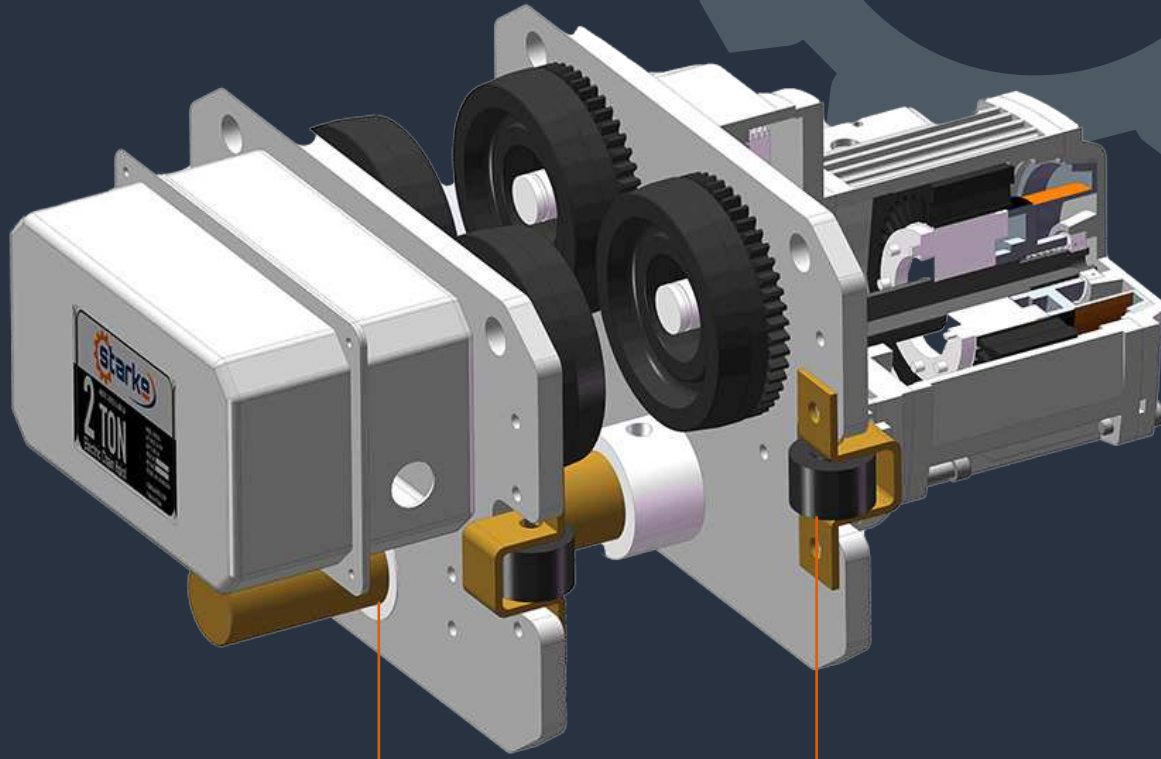

Single pin design
for easy adjustment
to beam width

Side guide rollers for
smooth movement

Load tested to 125%
of the rated capacity

FLANGE WIDTH

1 Ton: 2.3" - 7.5"

2 Ton: 3.2" - 9.0"

3 Ton: 3.9" - 7.9"

5 Ton: 3.9" - 7.9"

FEATURES

TRAVEL SPEED: 27-82 FPM VS

CAPACITY: 1-5 TON

METRIC RATED CAPACITY

VOLTAGE: 460/3/60 Hz