



OWNER'S MANUAL

IDRIVE

Beam Tractor Drive Operators Manual



Table of Contents

1.0 Safety.....	3
2.0 Warnings.....	3
3.0 Product Introduction.....	4
4.0 Adjusting Starke IDrive Width for the Beam Flange Width.....	4
5.0 Installing the Starke IDrive Tractor on the Beam.....	5
6.0 Adjusting the Starke IDrive Tractor Pressure Wheel Spring.....	5
7.0 Part Lists & Diagrams.....	8
7.1 Electric Trolley Assembly Drawing.....	8
7.2 Electric Trolley Part List.....	9
7.2 Electric Trolley Part List (Cont.).....	10
7.3 Pressure Wheel Assembly.....	12
7.4 Pressure Wheel Assembly Part List.....	Error! Bookmark not defined.
8.0 Product Drawings & Dimensions.....	13
8.1 Trolley Wheel Dimensions.....	13
8.2 Trolley Dimensions.....	14
9.0 Flange Width Adder.....	15
10.0 VFD Information.....	15
11.0 Wiring Diagram.....	16
Starke Products Warranty.....	17

▲IMPORTANT NOTE: Please read the below items before any operation of the unit is performed.

1.0 Safety

Because of heavy loads being moved or supported the operator and those around the area must be attentive to and aware of any risks involved with the operation of this unit. All Safety Rules must be followed, and the operator must pay attention to and abide by the warnings below and safety rules found throughout this manual.

2.0 Warnings

Before operation, the operator must have a clear and unobstructed view of the whole area.

Do not attach the electrical supply wires to this unit before the completion of installation!

Before operation, inspect the work area to make sure it is safe and clear of obstructions.

While operating the IDrive Trolley the operator must be careful to prevent a situation where the reverse force of changing direction causes the load to swing causing an overload of the trolley or loss of the load.

3.0 Product Introduction

Thank you for purchasing a Starke SBT30VS Tractor Drive Trolley. It is our intention that this product manual will address any concerns you may have about the operation or installation of your new trolley. This IDrive unit comes standard as a 460V 3ph unit. Please be aware that 230V 3 phase units are available also.

▲ IMPORTANT NOTE: Make sure that the power supply you intend to hook up to this new hoist matches the voltage of the trolley you have.

All models include VFD controls with adjustable parameters for specific required low and high speeds.

This Starke IDrive Trolley comes standard as a 2-speed trolley.

This Starke IDrive Trolley comes with a standard clevis type connection to your tow bar.

Flange width adder kits are available for the Starke SBT30VS IDrive Trolleys. Please consult your dealer if your beam flange is larger than the ability of your trolley. Maximum flange widths for all units = 16"

4.0 Adjusting Starke IDrive Width for the Beam Flange Width

- 4.1 Allow a 4mm gap between auxiliary side guide wheels and the beam flange so that tractor can roll freely on the beam but not be too tight or too loose. Do this before attempting to install the tractor on the I-Beam. (Do not allow more than 4mm gap between auxiliary side guide wheels and the beam flange)
- 4.2 To set the spacing between the auxiliary side guide wheels 4mm larger than the beam flange width, begin by installing some of the adjusting spacers on the pressure wheel assembly support shafts. (Release pressure from the pressure wheel adjusting spring prior to adjustment if needed) Next, install the pressure wheel assembly between the side plates of the IDrive as closely as possible to centerline of I-beam. Add additional inner spacers to make the 4mm gap. (Beam flange width + 4mm = distance between side guide wheels. Adjust with spacers accordingly until as close to 4mm gap as possible is attained. Finally, install as many of the remaining spacers on the pressure wheel carriage shafts as possible and tighten shaft hardware.



4.2.1 Flange Width Shims

5.0 Installing the Starke IDrive Tractor on the Beam

- 5.1 If possible, the assembled tractor drive can be installed on the end of the beam without disassembly. If this is not possible proceed to the items below.
- 5.2 Remove the electric motor side of the IDrive from the pressure wheel support shafts making note of where the shim spacers are located.
- 5.3 With help, assemble the 2 halves of the IDrive Trolley onto your I beam and replace shims in the proper positions to establish the 4mm gap required.
- 5.4 Check that the green pressure wheel assembly is located on the centerline of your I beam.
- 5.5 It is important that you set the pressure spring on the pressure wheel to gain the traction needed to pull your assembly with the tow bar.

6.0 Adjusting the Starke IDrive Tractor Pressure Wheel Spring

6.1 Once installed on the I beam you will need to set the pressure on the green pressure wheel assembly.

6.2 Attach tow bar to your product you are towing and with very light pressure on the pressure wheel against the bottom of the beam try to pull the load. If the IDrive trolley slips increase pressure in $\frac{1}{2}$ turn increments on the pressure wheel adjusting nut that is located on the bottom of the pressure wheel assembly. Once the tractor wheels do not slip, adjust the pressure wheel adjusting nut $\frac{1}{2}$ turn for the final setting.

▲IMPORTANT NOTE: Adjusting the pressure wheel spring too tight will cause premature wear of the green poly material on the pressure wheel. Follow instructions above for correct setting. See page 12 for pressure wheel assembly.

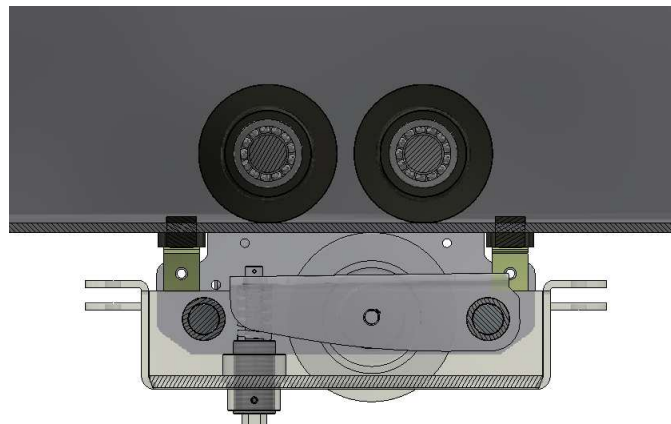

6.2.1 Diagram of Tractor Pressure Wheel Spring

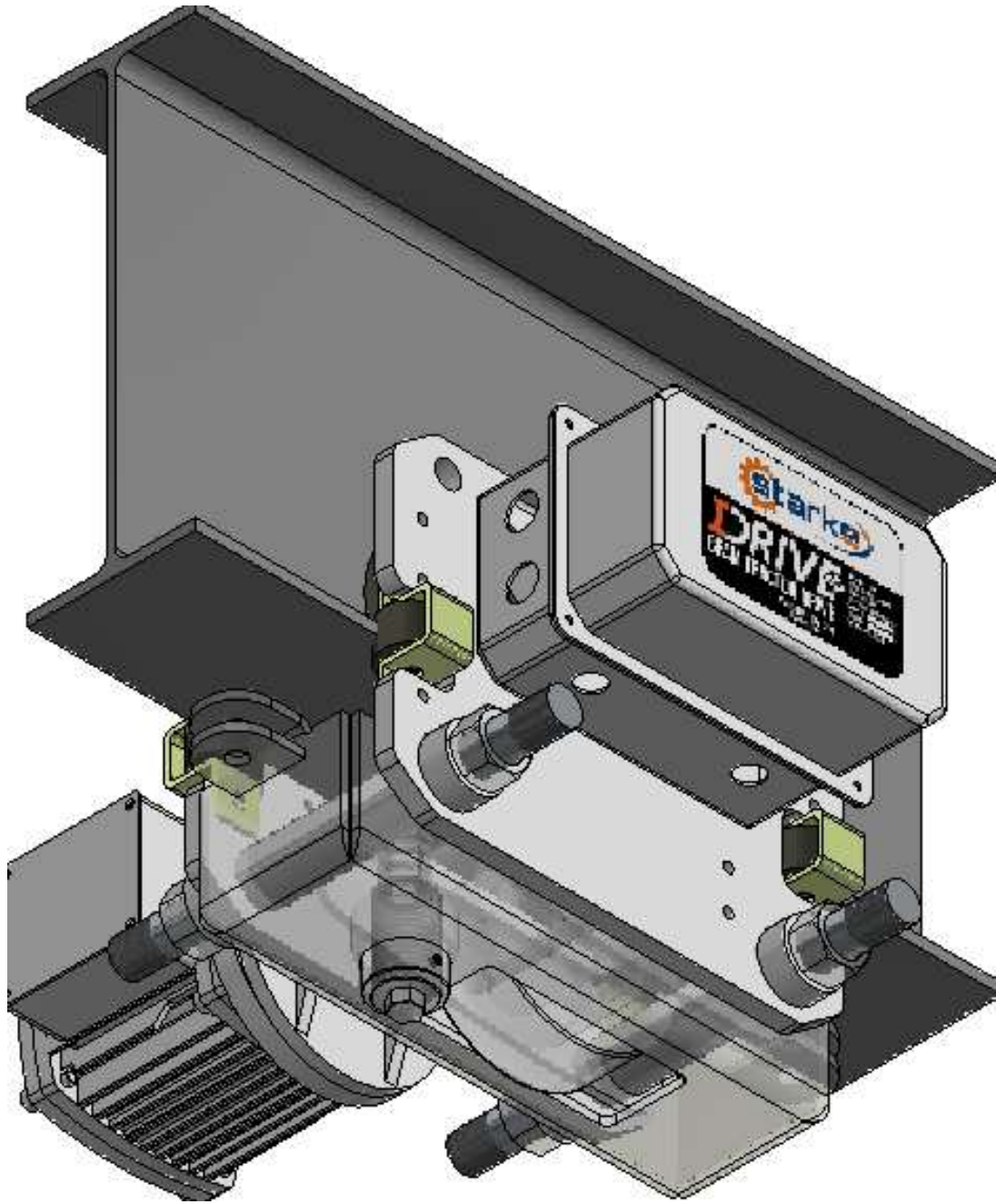

6.2.2 3D Model of Starke I-Drive on a Beam

(Intentionally Left Blank)

7.0 Part Lists & Diagrams

7.1 Electric Trolley Assembly Drawing

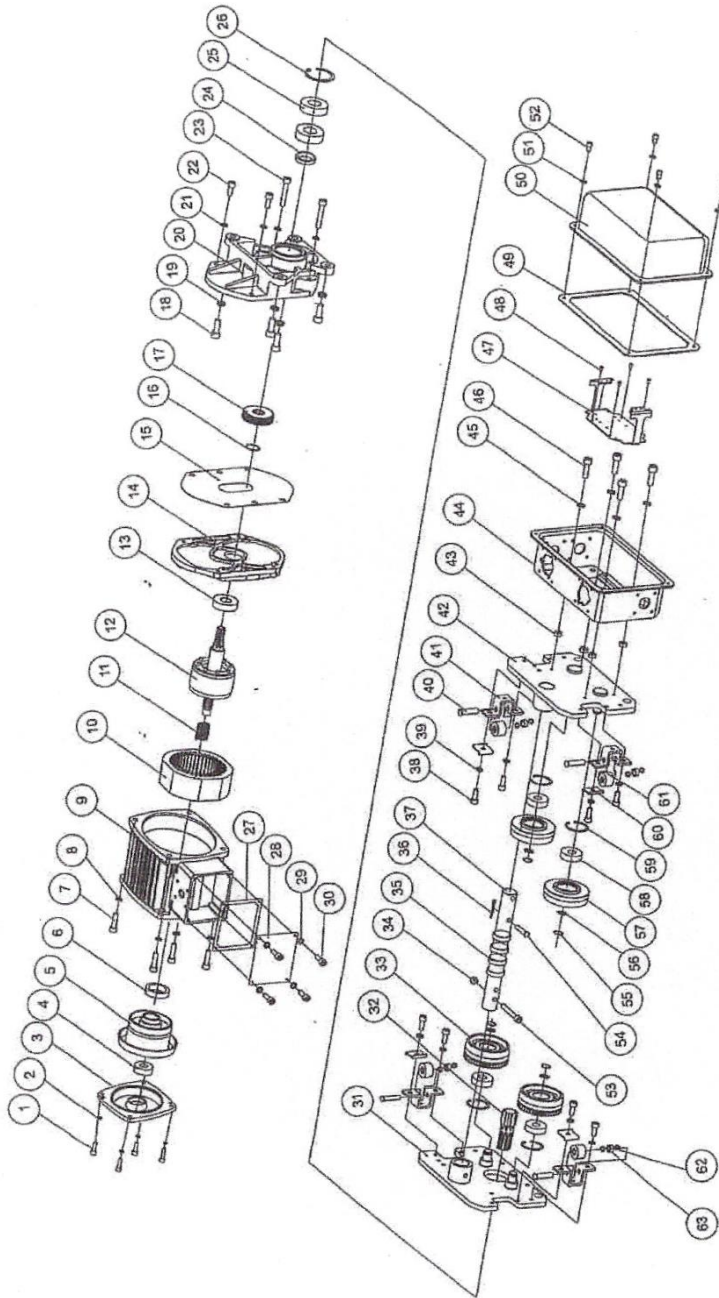

*See page 12 for the pressure wheel assembly

Drawing numbers marked with an asterisk designate parts as critical spares.

7.2 Electric Trolley Part List

Drawing No.	Part Description	Item Number	Qty
1a *	Complete Motor →	Complete Motor Assy Includes # 1-30 3 Ton - 1 HP 600-46024	1
1	Socket Head Cap Screw		4
2	Lock Washer M6		4
3	Motor End Cover		1
4	Ball Bearing 6202		1
5	Brake Assembly		1
6	Rubber Circlip		1
7	Socket Head Cap Screw		4
8	Lock Washer		4
9	Motor Shell		1
10	Stator		1
11	Spring		1
12	Rotor Assembly		1
13	Deep Groove Ball Bearing		1
14	Motor Bottom Plate		1
15	Motor Bottom Plate Gasket		1
16	Circlip		1
17	Gear		1
18	Socket Head Cap Screw		4
19	Spring Washer		4
20	Gearbox		1
21	Spring Washer		4
22	Socket Head Cap Screw		2
23	Socket Head Cap Screw		1
24	Seal		1
25	Bearing		2
26	Snap Ring		1
27	Side Plate Gasket		1
28	Side Plate		1
29	Lock Washer		4
30	Socket Head Cap Screw	4	
31	Side Plate Assem.	600-46053	1
32	Splined Gear Shaft	600-46057	1
33*	Geared Drive Wheel	600-40110	2
34	Lock Nut	600-46063	1
35	Adjusting Spacer	600-50171	8
36	Cotter Pin	600-46064	1
37	Trolley Pin	600-46122	1
38	Socket Head Cap Screw	600-46111	8
*	Danfoss VFD	DF132F0020 1.5KW 7HP	1

7.2 Electric Trolley Part List (Cont.)

Drawing No.	Part Description	Item Number	Qty
39	Lock Washer	600-46112	8
40	Auxiliary Wheel Shaft	600-46118	4
41	Auxiliary Wheel Bracket	600-46119	4
42	Trolley Sub Plate Assem.	600-46075	1
43	Gasket	600-46077	4
44	Control Case	600-46078	1
45	Lock Washer	600-46079	4
46	Socket Head Cap Screw	600-46105	4
47	Wire Connection Bracket	NSS	1
48	Screw	NSS	4
49	Control Case Gasket	600-46106	1
50	Control Case Cover	600-46107	1
51	Lock Washer	600-46108	4
52	Socket Head Cap Screw	600-46109	4
53	Socket Head Cap Screw	600-46110	1
54	Trolley Shaft Dowel Pin	600-46126	1
55	Circlip – Shaft	600-46112	4
56	Trolley Wheel Washer	600-46134	4
57*	Trolley Wheel – Idler	600-46114	2
58	Ball Bearing	NSS	4
59	Circlip – Bearing Retainer	NSS	4
60	Aux Wheel Retainer Bracket	600-46102	4
61*	Auxiliary Wheel	600-46103	4
62	Washer – Auxiliary Wheel	600-46104	8
63	Bearing – Auxiliary Wheel	NSS	4

(Intentionally Left Blank)

7.3 Pressure Wheel Assembly

PN: 600-46050

This part only comes as an assembly. Parts not sold separately.

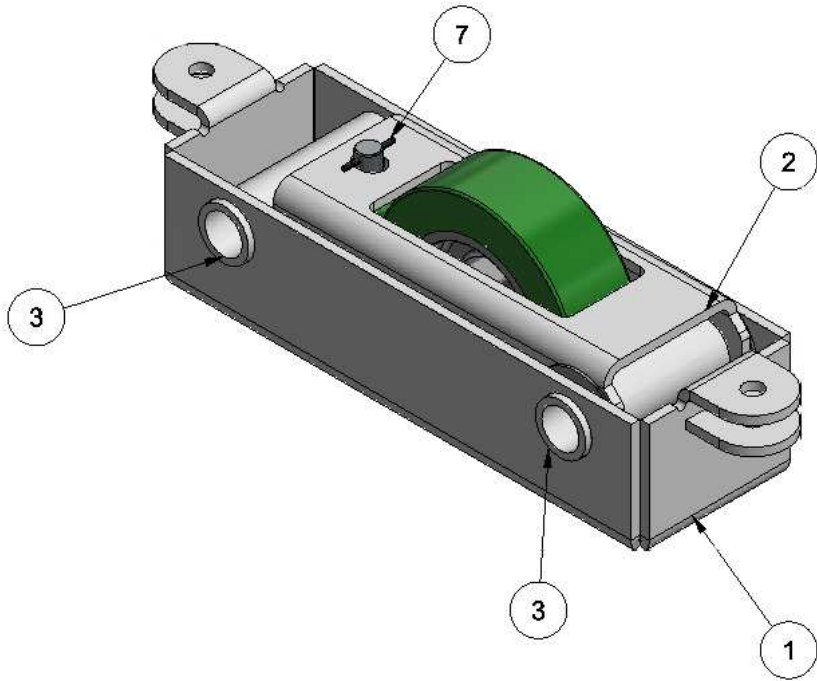

Information about the Danfoss VFD can be found on page 15.

8.0 Product Drawings & Dimensions

8.1 Trolley Wheel Dimensions

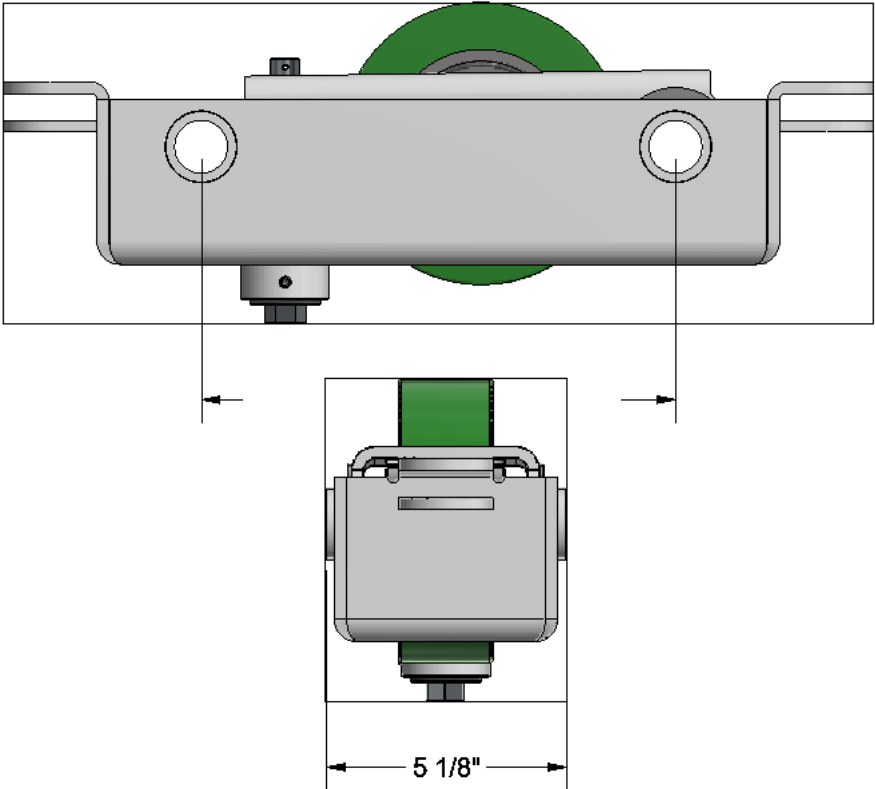
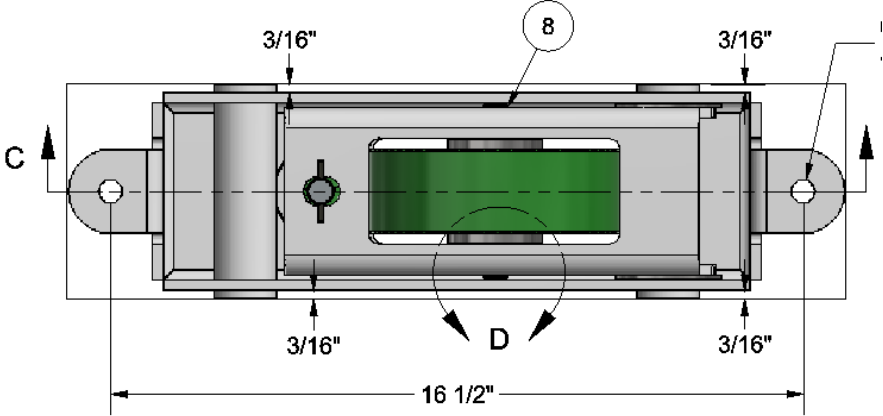

8.2 Trolley Dimensions

TOTAL WT.# 143

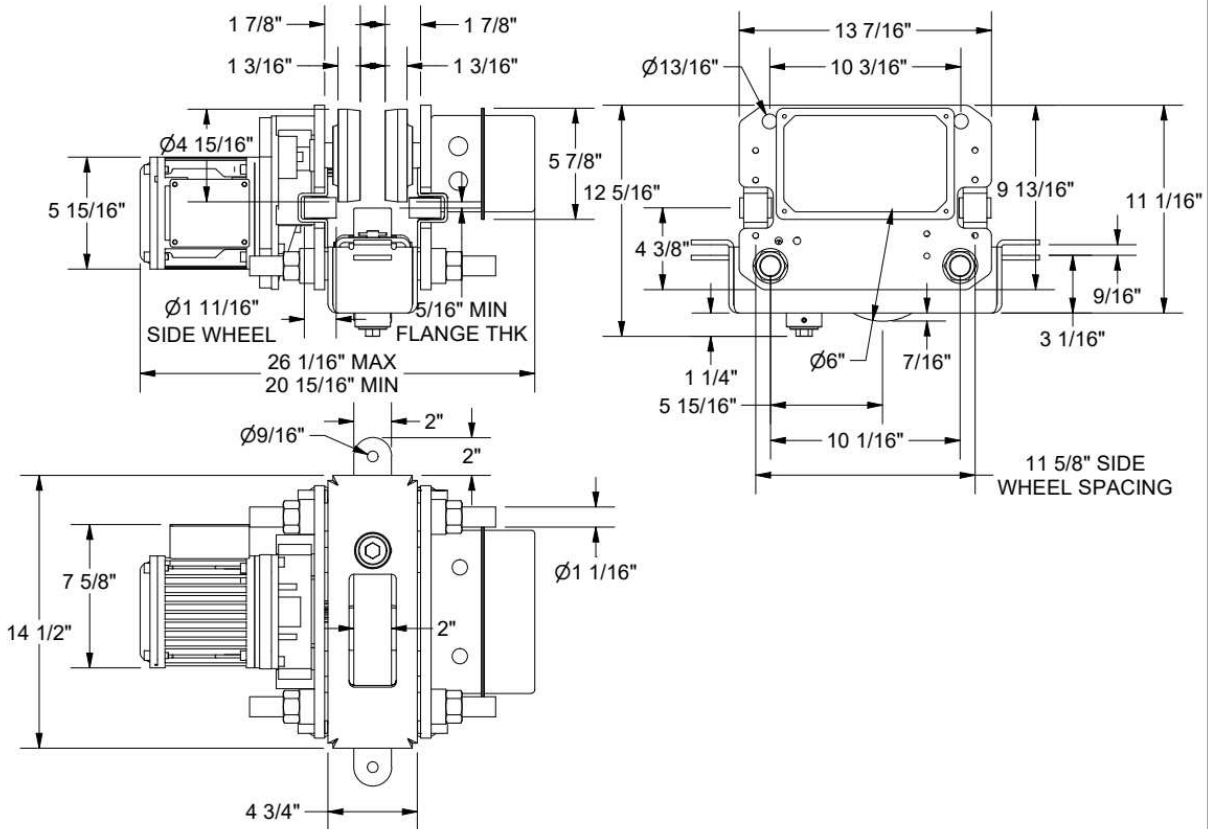
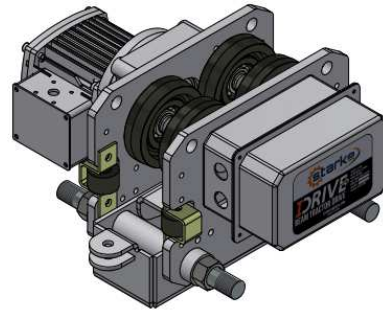
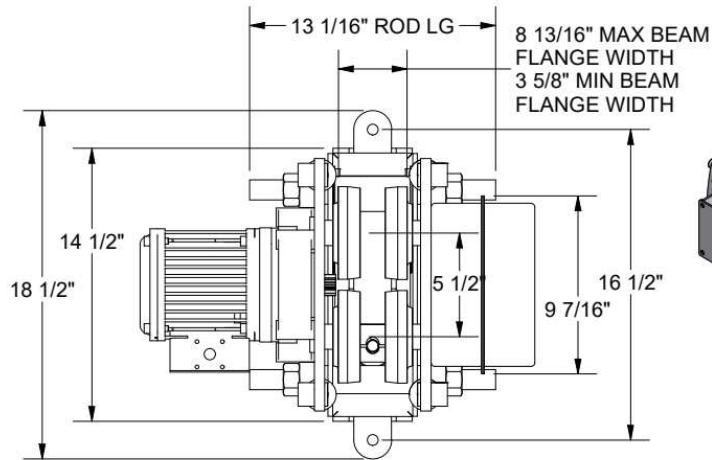

PAGE
1 OF 1

DRAWING:
I-DRIVE BEAM TRACTOR DRIVE
SBT30VS

TOLERANCES (U.N.O.):
DIMENSIONS: ±1/8"
ANGLES: ± 0.2°
MACHINING: ± 0.01"



9.0 Flange Width Adder

SKU	Cap	Flange Range
SMT30FW12	3 Ton	8" – 12"
SMT30FW16	3 Ton	12" – 16"

10.0 VFD Information

For more detailed information on VFD visit this link below:

https://files.danfoss.com/download/Drives/doc_MG02B622.pdf

Any alterations to VFD programming may adversely affect unit operational performance and potential safety issues. Before attempting any alterations, please contact your Starke representative.

11.0 Wiring Diagram

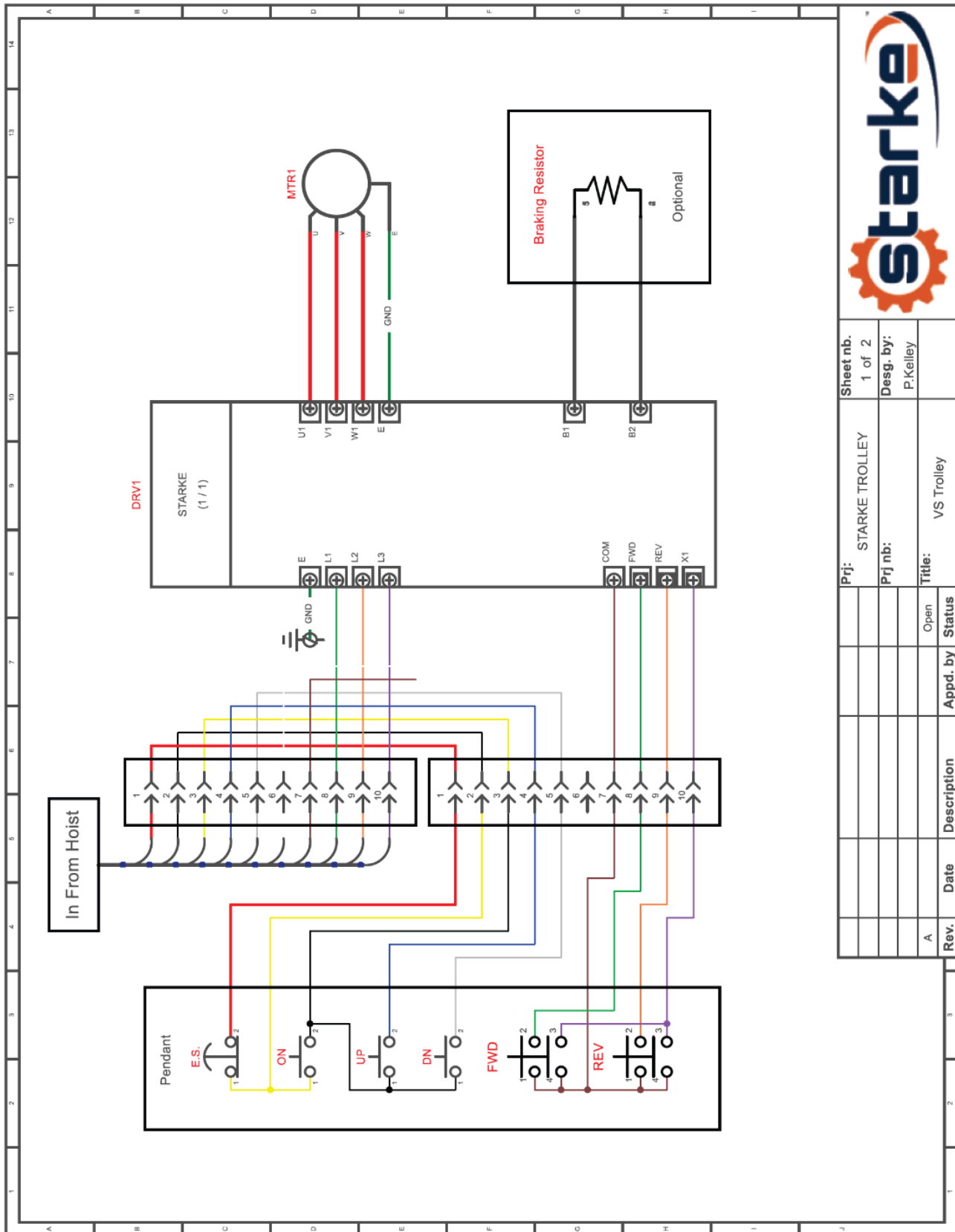

Rev.	Date	Description	Appd. by	Status
A				Open

Prj:	STARKE TROLLEY	Sheet nb.	1 of 2
Prj nb:		Desg. by:	P.Kelley
Title:	VS Trolley		



Starke Products Warranty

1 Year (12 Month) Parts & Labor Warranty

Unless otherwise specified, Starke guarantees that our products are free from material defects in design and workmanship under normal use, proper maintenance, and service.

This warranty is strictly limited to 12 months for single shift operation or 2,000 hours after installation, or 14 months after shipment, whichever is shorter. Within ten days after defect is found, warrantee must deliver a written notice to Starke providing defect information. All requested warranty information must be received promptly by Starke in no more than 5 business days.

Customer is responsible for all shipping charges on returned/warrantable items. Starke will cover the repair (parts and labor) at no charge or provide a replacement item at Starke's discretion.

This warranty does not cover defects or damage caused by acts of God, unusual wear and tear, improper use, or improper maintenance by the user. No responsibility for consequential damage is expressed or implied, and the responsibility under this warranty/guaranty is limited to the repair or replacement of the defective materials. Repair or replacement of the item is fully at the discretion of Starke.

ALL OTHER REPRESENTATIONS, EXPRESS OR IMPLIED, WARRANTY, OR LIABILITY RELATING TO THE CONDITION OR USE OF THE PRODUCT ARE SPECIFICALLY DISAVOWED, AND IN NO EVENT SHALL STARKE BE LIABLE TO BUYER, OR ANY THIRD PARTY, FOR ANY DIRECT OR INDIRECT CONSEQUENTIAL OR INCIDENTAL DAMAGES

STARKE

Starkeamerica.com/contact-us/



Contact Your Starke Representative for More Information on Products to Help Maximize Your Workplace Efficiency



Hoists & Trolleys



Crane Components



Electrification

Crane Kits



Slings



Safety